

APA-04H

APARCABICILETAS URBANO (1 PLAZA)
BICYCLE STAND "URBAN" (1 PLACE)
RÂTELIER À VÉLO "URBAIN" (1 PLACE)

FICHA TÉCNICA TECHNICAL DATA SHEET FICHE TECHNIQUE

* **Dimensiones** 160 x 160 x 700 mm.

Dimensions
Dimensions

* **Estructura** Acero

Structure Steel
Structure Acier



es

Aparcabicicletas individual donde el usuario podrá aparcar su bicicleta introduciendo la rueda entre la horquilla. Formado por una pletina de acero de 8mm de espesor curvada, formando una "U" invertida, y soldada a la plancha de acero circular de Ø160mm que irá anclada al suelo.

Aparcabicicletas apto para uso bilateral. Apto para ruedas anchas (BTT).

en

Individual bicycle stand where the user can park his bike introducing the wheel in the fork.

It is formed by a curved steel plate of thickness 8mm, representing an inverted U-shape, and welded to a circular steel plate of Ø160mm which will be mounted on the ground.

Bicycle stand suitable for usage from both sides. Suitable for wide wheels (mountain bikes).

fr

Râtelier à vélo individuel où on peut ranger sa bicyclette on mettant la roue entre la fourche. Formé par une pléatine d'acier courbé de 8mm de l'épaisseur, formant un U inversé, et soudé à une planche d'acier circulaire de Ø160mm, qui sera attaché à la surface.

Râtelier à vélo apte pour usage bilateral. Apte pour des pneus larges (VTT).

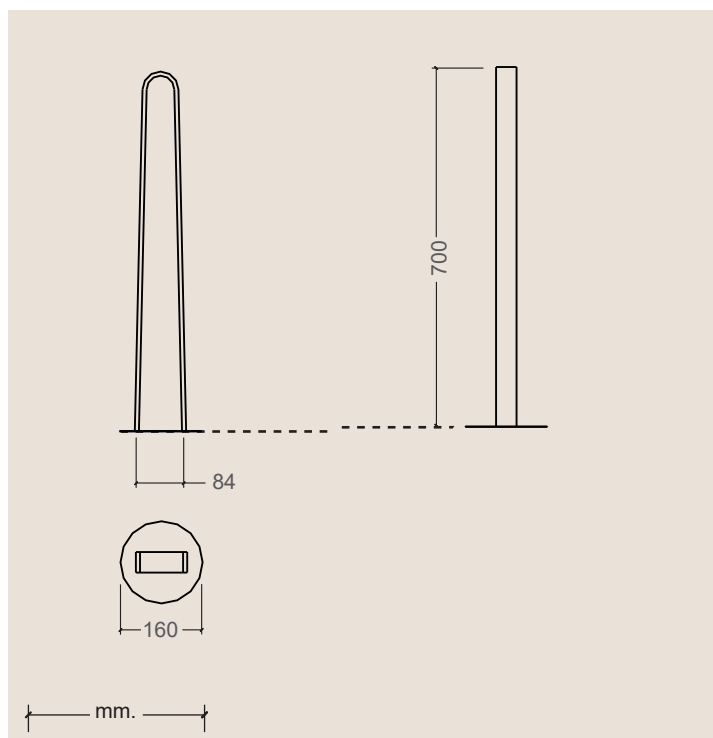

mobipark ESPAÑA

Pol Ind. Cantavella Calle Lliria, 8
46135 Albalat dels Sorells (Valencia) Spain

T. +34 96 149 45 12
F. +34 96 149 46 02

mobipark@mobipark.com
www.mobipark.com

**mobipark**
PARQUES INFANTILES MOBILIARIO URBANO